

## ANSI 600# RF Single Basket Strainer Bolted and Quick Open Style

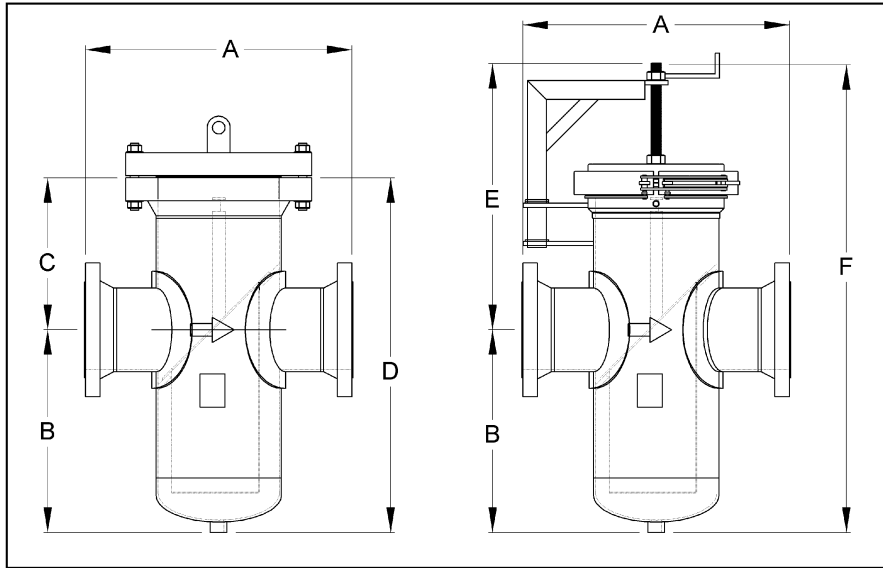

### Standard Feature

- Bolted access cover c/w NAF gasket
- Series G closure c/w Viton seal
- 1/8" Perforated Stainless Steel (304) Basket
- 1/2" NPT Vent, NPT Drain

Line Size	Body Dia	A	B	C	D	E	F	Drain NPT	Weight Bolted	Weight QOC
2	4.50	17	8	7	15	n/a	n/a	3/4	135	n/a
3	6.625	20	12	8	20	23	35	3/4	275	305
4	8.825	24	14	9	23	25	39	3/4	450	510
6	10.75	28	18	10	28	26	44	1	780	870
8	12.75	32	21	12	33	29	50	1	1100	1160
10	14	34	24	14	38	31	55	1	1420	1580
10	16	36	24	14	38	32	56	1 1/2	1780	1980
12	16	38	24	16	40	34	58	1 1/2	1940	2155
12	18	42	28	17	44	35	63	1 1/2	2290	2540
14	18	44	29	17	45	35	64	1 1/2	2440	2710
16	20	48	30	18	48	37	67	2	3150	3520
16	24	52	39	20	59	40	79	2	4350	4835
18	24	54	39	20	59	40	79	2	4570	5075
20	24	56	43	24	67	44	87	2	5100	5670
20	30	60	51	30	81	52	103	2	5800	6410
24	30	62	51	30	81	52	103	2	6600	7335